



# Gas and Air Mixers

GM 50-01 • GM 100-01 • GM 140-01 • GM 200-01 • GM 300-01

## DESCRIPTION

The gas and air mixer is an indispensable component of the fuel system. Whilst the throttle valve controls the quantity of the mixture, the mixing unit takes care for quality of the mixture. HEINZMANN mixers provide a very homogeneous air and gas mixture and an optimal Air to Fuel Ratio over the entire speed and load range of the engine. HEINZMANN also can supply the remaining components of the fuel system such as main adjusting screw, zero pressure regulator, throttle valve, speed and load control, AFR-controls for stoichiometric as well as for lean burn, adaptors, levers etc..

## FEATURES

- Mixes gas and air to a very homogenous mixture
- Automatic metering of the gas at any air flow according to Bernoulli's law
- Cost effective and maintenance free fuel system component without moving parts
- Very low pressure drop due to the almost ideal shaped venturi insert
- Applicable for a wide range of gasses e.g. from landfill gas to propane
- Adaptable matching throttle valve or hose connector
- Suitable for naturally aspirated and turbo charged engines
- The carburettors can be configured as draw through as well as blow through
- The carburettor models are also available for dual gas, EGR and low calorific gasses
- Supplied with balance line connector in order to compensate for air filter restriction
- For corrosive gases the components are also available in anti corrosive versions
- The mixer insert is OEM configurable and removable

## APPLICATION RANGE

Mixer Size	Gas Engine Output Range in kW *			
	Stoichiometric		Lean burn **	
	min.	max.	min.	max.
Size 50	35	125	25	85
Size 100	70	250	50	170
Size 140	140	500	100	340
Size 200	330	1200	230	840
Size 300	750	2250	500	1500

\* Power at Draw Through carburetion. In Blow Through application the output will be 50 % to 150 % higher, dependent on the boost pressure.

\*\* Power at an Air to Fuel Ratio of about 1,6



For dimensions of mixers and mounting plates see overleaf

**Fritz Heinzmann GmbH & Co. Speed Governors**

Am Haselbach 1 • D-79677 Schönau (Schwarzwald)

Tel. +49 (0)7673 8208-0 • Fax +49 (0)7673 8208-188

e-Mail: info@heinzmann.de • www.heinzmann.de

Size 50

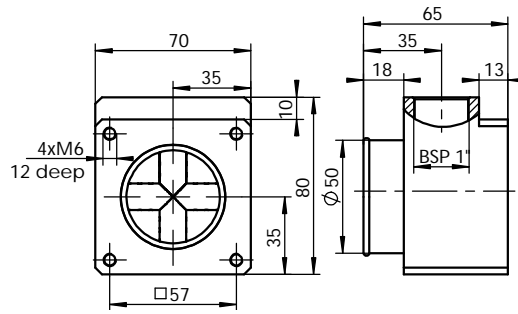

Size 100

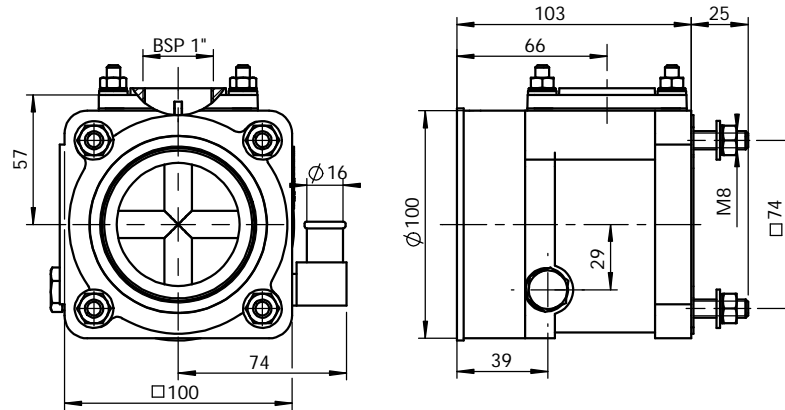

Size 140

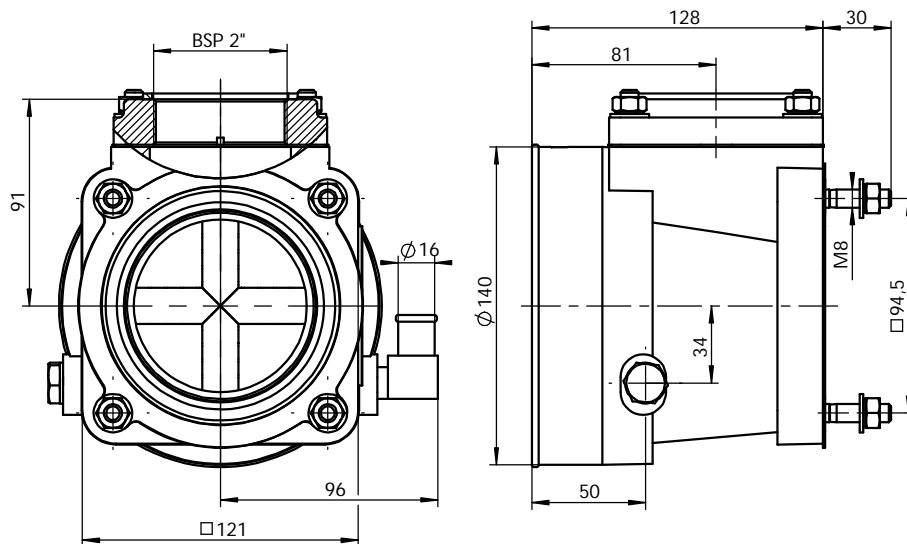

Size 200

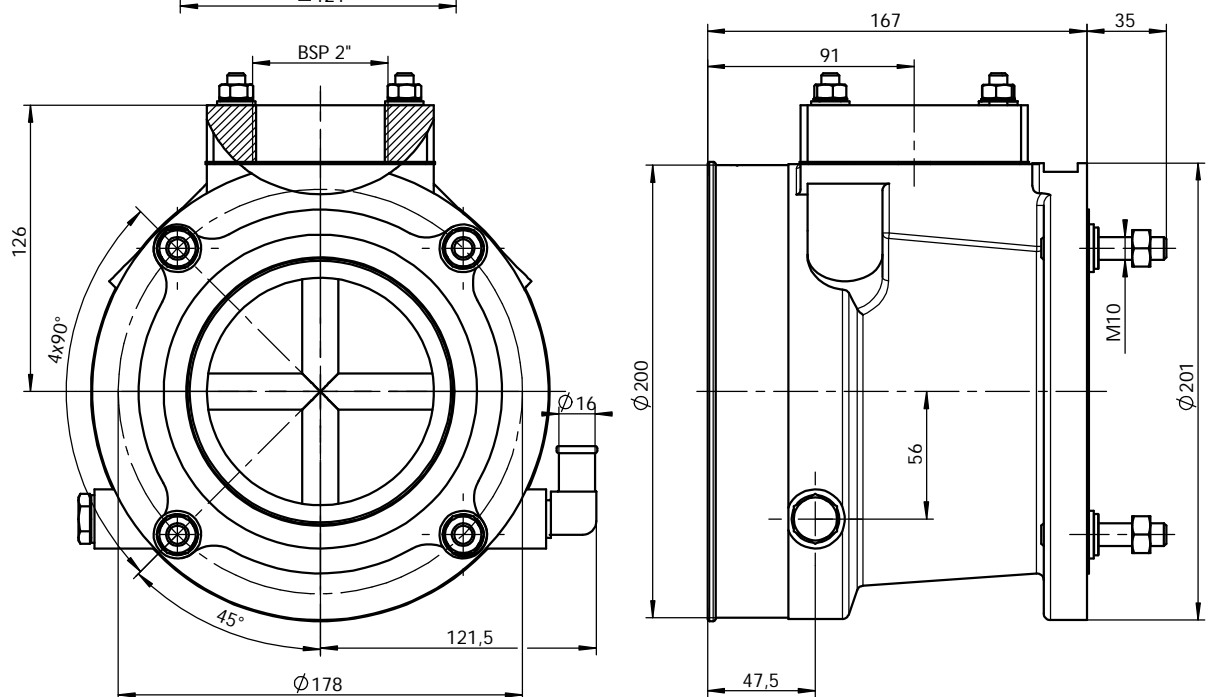

Dimensions for Size 300 on inquiry